

**IF YOU DO NOT MEASURE IT,  
YOU CANNOT IMPROVE IT**

## **FUEL & ENERGY EFFICIENCY MONITORING SYSTEMS**

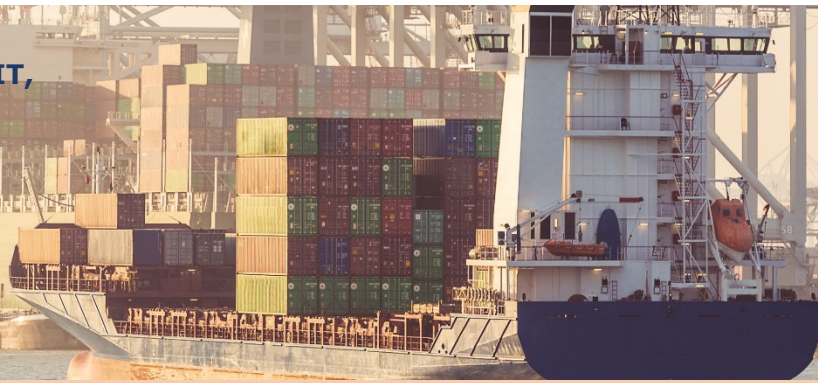

Our fuel and energy efficiency monitoring systems measure besides the fuel oil consumption, the various KPI's that make up and influence your ships efficiency. The data is processed through a PLC and graphically displayed on a touch screen panel.

The systems are of a modular design and can measure data from up to two main engines with associated propulsion trains and up to four auxiliary consumers with various energy outputs. For each individual consumer the system can record up to three different types of fuel oil (or gas). From the navigation bridge data from GPS, speed log, wind meter and echo sounder are recorded.

Besides actual consumption and efficiencies, daily (24 hour) counters and separate voyage counters are available, as well as a speed trial functionality for determining the propulsion and hull performance. Various dashboards, graphs and alarm settings complete the systems functionalities.

The system communicates over the ships Ethernet, making it unnecessary to install additional cabling from the engine room to the navigation bridge. We can arrange the complete installation and commissioning, including the integration with the various ships systems.

Remote access for real time information, service, system checks and data gathering are possible without interference of the ship's crew.

Tens of thousands of tons of fuel oil have been saved with these system. Also emissions of greenhouse gasses have been reduced with up to hundreds of thousands of tons. Not to mention the huge reduction in financial costs.



IF YOU DO NOT MEASURE IT,  
YOU CANNOT IMPROVE IT

# FUEL & ENERGY EFFICIENCY MONITORING SYSTEMS

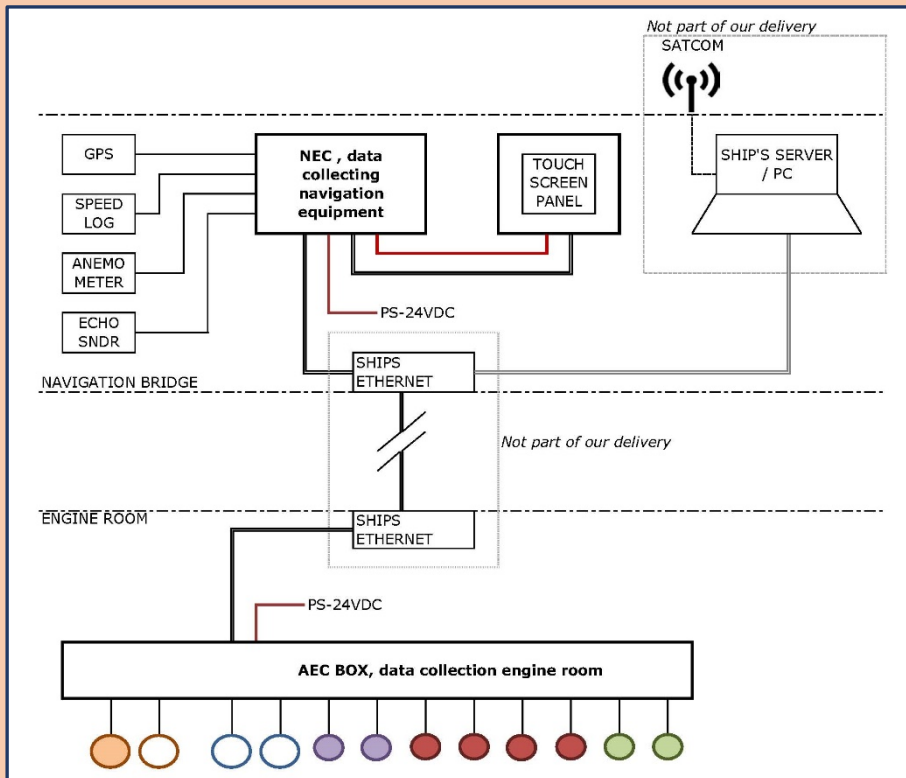

Each system consists of three main components:

- Touch screen Panel
- NEC box
- AEC box

And when required, complemented with:

- Fuel Oil (Gas) Meters
- Torque meters
- Temperature Sensors
- Signal Converters

## Features

- Up to 10 independent different fuel oil consumers in one system
- Up to 3 different fuel oils independently counted for per consumer
- Suitable for LNG / dual fuel executions
- Automatic MRV / IMO (CO<sub>2</sub>) reporting
- Various other reports generated automatically
- Reports are easily accessible and can be opened in Excel
- All measured and calculated values are available over MODBUS for use in other applications/databases
- Automatic data transmittal to shore possible
- Remote access from shore possible for real time information
- Remote access for shore assistance in case of operational problems
- Intuitive screens and information
- Optional connection possible to on line analysis software for complete fleet monitoring

Contact us for more detailed information or presentation.